

Performance of planar-waveguide external cavity laser for precision measurements

Kenji Numata,^{1,2,*} Jordan Camp,² Michael A. Krainak,² and Lew Stolpner³

¹Department of Astronomy, University of Maryland, College Park, Maryland, 20742, USA

²NASA Goddard Space Flight Center, Greenbelt, Maryland, 20771, USA

³Redfern Integrated Optics Inc., 3350 Scott Blvd, #62, Santa Clara, California, 95054, USA

*kenji.numata@nasa.gov

Abstract: A 1542-nm planar-waveguide external cavity laser (PW-ECL) is shown to have a sufficiently low level of noise to be suitable for precision measurement applications. Its frequency noise and intensity noise is comparable or better than the non-planar ring oscillator (NPRO) and fiber laser between 0.1 mHz to 100 kHz. Controllability of the PW-ECL was demonstrated by stabilizing its frequency to acetylene ($^{13}\text{C}_2\text{H}_2$) at 10^{-13} level of Allan deviation. The PW-ECL also has the advantage of the compactness of a standard butterfly package, low cost, and a simple design consisting of a semiconductor gain media coupled to a planar-waveguide Bragg reflector.

©2010 Optical Society of America

OCIS codes: (140.2020) Diode lasers; (140.3425) Laser stabilization; (300.6390) Spectroscopy, molecular.

References and links

1. T. J. Kane, and R. L. Byer, "Monolithic, unidirectional single-mode Nd:YAG ring laser," *Opt. Lett.* 10(2), 65–67 (1985).
2. B. C. Barish, and R. Weiss, "LIGO and the detection of gravitational waves," *Phys. Today* 52(10), 44 (1999).
3. L. Bartelt-Berger, F. Heine, U. Hildebrand, D. Lange, S. Seel, T. Schwinder, and B. Smutny, "Space qualified ultra stable laser source," *Lasers and Electro-Optics, 2001. CLEO '01. Technical Digest.*, pp.580–581, (2001).
4. K. Liu, and M. G. Littman, "Novel geometry for single-mode scanning of tunable lasers," *Opt. Lett.* 6(3), 117–118 (1981).
5. C. J. Hawthorn, K. P. Weber, and R. E. Scholten, "Littrow configuration tunable external cavity diode laser with fixed direction output beam," *Rev. Sci. Instrum.* 72(12), 4477 (2001).
6. A. D. Ludlow, X. Huang, M. Notcutt, T. Zanon-Willette, S. M. Foreman, M. M. Boyd, S. Blatt, and J. Ye, "Compact, thermal-noise-limited optical cavity for diode laser stabilization at 1×10^{-15} ," *Opt. Lett.* 32(6), 641–643 (2007).
7. J. Alnis, A. Matveev, N. Kolachevsky, Th. Udem, and T. W. Hänsch, "Subhertz linewidth diode lasers by stabilization to vibrationally and thermally compensated ultralow-expansion glass Fabry-Pérot cavities," *Phys. Rev. A* 77(5), 053809 (2008).
8. L. Dong, W. H. Loh, J. E. Caplen, J. D. Minelly, K. Hsu, and L. Reekie, "Efficient single-frequency fiber lasers with novel photosensitive Er/Yb optical fibers," *Opt. Lett.* 22(10), 694–696 (1997).
9. C. P. Spiegelberg, "Compact 100 mW fiber laser with 2 kHz linewidth," in *Optical Fiber Communication Conference, Technical Digest (Optical Society of America, 2003)*, paper PD45.
10. Redfern Integrated Optics Inc, <http://www.rio-inc.com/>, (California, USA).
11. M. Alalusi, P. Brasil, S. Lee, P. Mols, L. Stolpner, A. Mehnert, and S. Li, "Low noise planar external cavity laser for interferometric fiber optic sensors," *Proc. SPIE* 7316, 73160–X (2009).
12. M. Tröbs, L. d'Arcio, G. Heinzel, and K. Danzmann, "Frequency stabilization and actuator characterization of an ytterbium-doped distributed-feedback fiber laser for LISA," *J. Opt. Soc. Am. B* 26(5), 1137 (2009).
13. J. L. Hall, L. Hollberg, T. Baer, and H. G. Robinson, "Optical heterodyne saturation spectroscopy," *Appl. Phys. Lett.* 39(9), 680 (1981).
14. P. Balling, M. Fischer, P. Kubina, and R. Holzwarth, "Absolute frequency measurement of wavelength standard at 1542nm: acetylene stabilized DFB laser," *Opt. Express* 13(23), 9196–9201 (2005).
15. D. Shaddock, B. Ware, P. G. Halverson, R. E. Spero, and B. Klipstein, "Overview of the LISA phasemeter," *AIP Conf. Proc.* 873, 654 (2006).
16. C. S. Edwards, H. S. Margolis, G. P. Barwood, S. N. Lea, P. Gill, and W. R. C. Rowley, "High-accuracy frequency atlas of $^{13}\text{C}_2\text{H}_2$ in the 1.5 μm region," *Appl. Phys. B* 80(8), 977–983 (2005).
17. V. Leonhardt, J. H. Chow, and J. B. Camp, "Laser frequency stabilization to molecular resonances for TPF-C, LISA, and MAXIM," *Proc. SPIE* 6265, 62652M (2006).
18. R. E. Bartolo, C. K. Kirkendall, V. Kupersmidt, and S. Siala, "Achieving narrow linewidth, low phase noise external cavity semiconductor lasers through the reduction of $1/f$ noise," *Proc. of SPIE* 61333, 61330I, (2006).

19. E. Rønnekleiv, "Frequency and intensity noise of single frequency fiber Bragg grating lasers," *Opt. Fiber Technol.* 7(3), 206–235 (2001).
 20. G. A. Cranch, M. A. Englund, and C. K. Kirkendall, "Intensity noise characteristics of Erbium-doped distributed-feedback fiber lasers," *IEEE J. Quantum Electron.* 39(12), 1579–1586 (2003).
 21. S. Huang, Y. Feng, J. Dong, A. Shirakawa, M. Musha, and K. Ueda, "1083 nm single frequency ytterbium doped fiber laser," *Laser Phys. Lett.* 2(10), 498–501 (2005).
 22. M. Tröbs, P. Weßels, and C. Fallnich, "Power- and frequency-noise characteristics of an Yb-doped fiber amplifier and actuators for stabilization," *Opt. Express* 13(6), 2224–2235 (2005).
-

1. Introduction

Telecom technology has evolved dramatically over the last decades. Better, smaller, and more cost-effective integrated optical components have been introduced into the telecom market, and are finding a number of applications for interferometric sensing. The planar external cavity diode laser (PW-ECL) we tested here is based on technology initially developed for telecom applications and later optimized for low frequency noise. We show that it has advantages for precision measurements.

The NPRO [1] is the present standard for low-noise interferometric sensing applications, employing a relatively simple configuration of a gain media (Nd:YAG crystal for 1064 nm and 1319 nm) used as a ring cavity. Due to its low frequency and intensity noise and the simple structure, it is widely used in various fields, including gravitational wave interferometers [2] and space telecommunications [3].

External (or "extended") cavity diode lasers (ECLs) based on Littman [4] and Littrow [5] configurations have wide tuning range and narrow linewidth. They have been used for optical clocks and high-precision spectroscopy, achieving 10^{-15} level frequency stability with rigid optical cavities [6,7].

Fiber laser performance is improving and replacing NPROs and Littman ECLs in various fields, especially where a fiber-coupled output is preferred. The large gain-bandwidth of fiber lasers allows flexible selection of the lasing wavelength. With special highly-doped gain fibers, single-mode lasing and simple frequency tuning have been achieved [8,9].

As a possible alternative to those lasers, we evaluated a PW-ECL, developed for optical sensing applications and available for 1550-nm spectral range, including dense wavelength division multiplexing (DWDM) international telecommunication union (ITU) channels. The butterfly packaged PW-ECL is smaller, simpler and lower cost than lasers of similar performance. This ECL uses a planar Bragg reflector on a planar silica waveguide to form a DBR (distributed Bragg reflector) laser cavity.

To fully investigate the stability of the PW-ECL, we stabilized its frequency by locking to acetylene ($^{13}\text{C}_2\text{H}_2$) Doppler-free absorption line. We also systematically compared its free-running frequency and intensity noise with other types of single-frequency lasers to evaluate its use for high-precision measurements. The PW-ECL turned out to have lower noise than most of the other types of lasers we tested. The simple structure, high performance, and especially, compactness of the PW-ECL make it attractive for use in compact optical frequency standards and space missions.

2. Planar-waveguide external cavity laser

We tested here a commercial laser module (named ORION), built by Redfern Integrated Optics [10]. The module includes a butterfly-packaged PW-ECL (named PLANEX), current drivers, a frequency tuning terminal (mentioned later), and a digital control interface. The size of the module is approximately 102 mm \times 57 mm \times 13 mm.

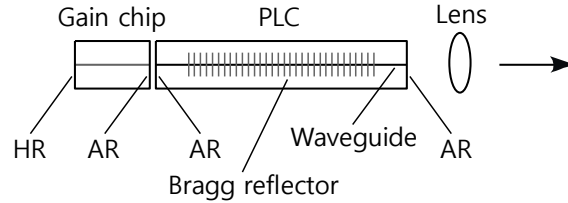

Fig. 1. Schematic of the PW-ECL [11]. HR: high-reflective coating, AR: anti-reflective coating, PLC: planar lightwave circuit. The output is PM fiber-coupled within the butterfly package after the lens and an optical isolator.

Figure 1 shows schematic of the cavity of the PW-ECL. The laser cavity is formed by two reflectors: a high-reflective (HR) coated facet on an InP multiple quantum well gain chip, and an anti-reflection (AR) coated waveguide grating formed in a silica-on-silicon planar lightwave circuit (PLC). All components are integrated into a standard 14-pin butterfly package on top of a thermoelectric cooler (TEC). The narrow reflection peak of the Bragg reflector in the PLC enables stable, low-noise, single-mode lasing at a selected wavelength within the telecom C-band (1528~1565 nm). For the study reported here, we chose 1542.383 nm as a lasing wavelength, allowing the P(16) line of $^{13}\text{C}_2\text{H}_2$ to be used as a frequency reference for the laser. The output is pigtailed with a polarization-maintaining (PM) fiber. The maximum output power is ~15 mW at ~180-mA injection current. The relationship between injection current and output power, optical spectrum, and frequency (phase) noise performance at high frequency of the PW-ECL was previously published [11].

3. Frequency tuning

Frequency tuning of the PW-ECL can be performed by adjusting the temperature of TEC or by adjusting the injection current.

3.1 Temperature adjustment

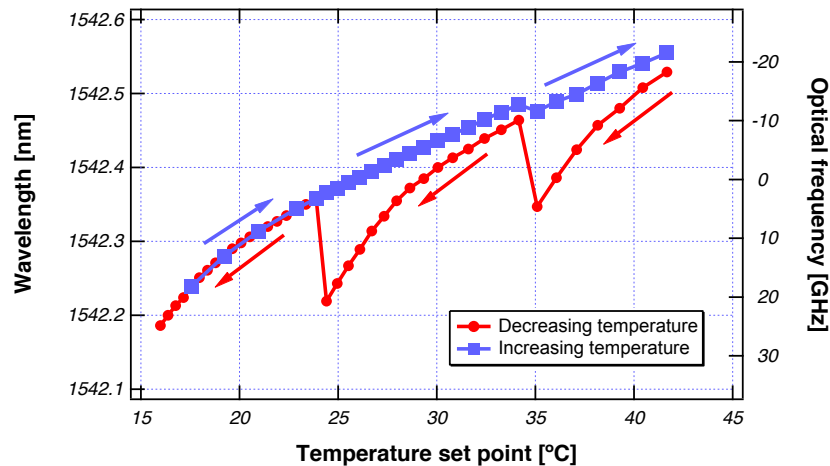

Fig. 2. Frequency (wavelength) tuning by temperature adjustment. Right axis represents optical frequency difference from 1542.383 nm. Circled and squared markers represent tuning results with decreasing and increasing set temperature, respectively.

Figure 2 shows frequency (wavelength) tuning of the PW-ECL by temperature adjustment. By using 16 ~42 °C temperature set points, ~0.37 nm (~47 GHz) tuning range was obtained around the nominal lasing wavelength, 1542.383 nm. As shown in Fig. 2, the thermal tuning has hysteresis, and may cause mode hops within the tuning range, depending on the thermal history the PW-ECL experienced. However, since the transition between modes happens smoothly, we generally did not observe stable two mode lasing or mode hopping.

3.2 Injection current adjustment

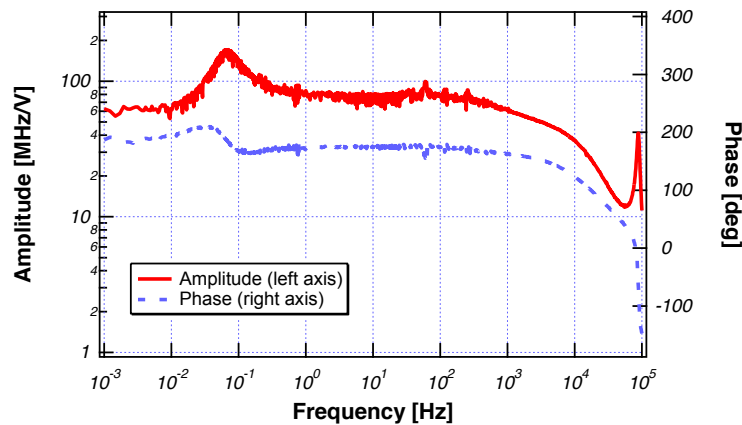

Fig. 3. Frequency tuning transfer function of the PW-ECL through injection current tuning terminal.

Figure 3 shows frequency tuning response as a function of the modulation frequency of voltage applied to injection current tuning terminal. This was measured by an anti-symmetric fiber Michelson interferometer (above ~ 10 Hz) and a beat-note between two PW-ECLs (below ~ 10 Hz), with a modulation signal applied to the electrical tuning terminal. The injection current directly modulates the optical frequency through thermal effects at low frequency. As any LD direct modulation, it results in a slight output power change as well. The thermal nature limits the 3-dB tuning bandwidth to ~ 2 kHz. Below this frequency, the transfer function is mostly constant down to 1 mHz. There is an increase in efficiency around ~ 0.1 Hz, probably due to coupling between the TEC thermal control and the current tuning. A peak at ~ 88 kHz is due to electrical resonance in the driving circuit, and not related to laser properties, such as mechanical resonance in fiber lasers [12]. The tuning range via the current tuning terminal was about 600 MHz.

4. Frequency noise

4.1 Frequency stabilization setup

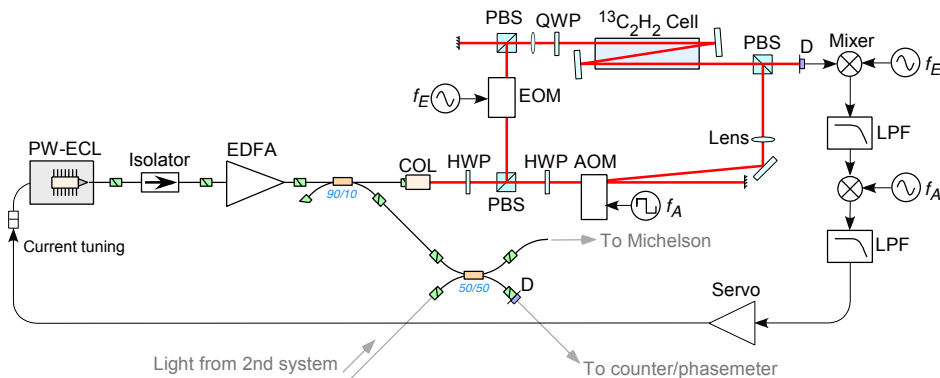

Fig. 4. Frequency stabilization setup using acetylene ($^{13}\text{C}_2\text{H}_2$). EDFA: Erbium-doped fiber amplifier, COL: fiber collimator, HWP: half waveplate, QWP: quarter waveplate, AOM: acousto-optic modulator, EOM: electro-optic modulator, PBS: polarized beamsplitter, D: photo-detector, LPF: low-pass filter, f_E : EOM modulation frequency (~ 20 MHz), f_A : AOM modulation frequency (~ 3 kHz).

Figure 4 shows our frequency stabilization setup, which uses the optical heterodyne saturation spectroscopic technique [13]. The 15-mW output of the PW-ECL was amplified by a PM Erbium-doped fiber amplifier (EDFA) to 320 mW. 10% of the output was split out for frequency noise measurements by a fiber coupler, while the remaining 90% was split into two paths by a polarized beamsplitter, after being coupled out of a fiber collimator. One of the beams was used as pump beam. It was chopped at ~ 3 kHz and frequency-shifted by 55 MHz by an acousto-optic modulator (AOM). The other beam was phase-modulated by an electro-optic modulator (EOM) at ~ 20 MHz and used as a probe beam. The case temperature of the EOM was stabilized to minimize frequency drift due to the residual amplitude modulation. The two beams were counter-propagated within a $^{13}\text{C}_2\text{H}_2$ cell with a pressure of 0.03 Torr and a length of 20 cm. Each beam made three passes through the cell. The P(16) transition of acetylene line at 1542.383 nm [14] was used in this system. The probe beam was detected by a photo-detector, whose signal was mixed down at both the EOM and AOM modulation frequencies. The demodulated signal was filtered by a servo circuit and fed back to the current tuning terminal of the PW-ECL. We kept the temperature set point constant and did not use the temperature tuning in a control loop, since the frequency drift was small and the current tuning range was large enough.

4.2 Frequency stabilization results

Slow frequency noise (up to 100 Hz) was evaluated using a beat-note between two identical systems. The beat-note was measured by a counter or a phasemeter [15], and converted to a frequency noise spectrum. At higher frequency, the noise was measured by the anti-symmetric fiber Michelson interferometer. The interferometer was set in a vacuum tank on rubber stacks in order to avoid any acoustic and seismic disturbances.

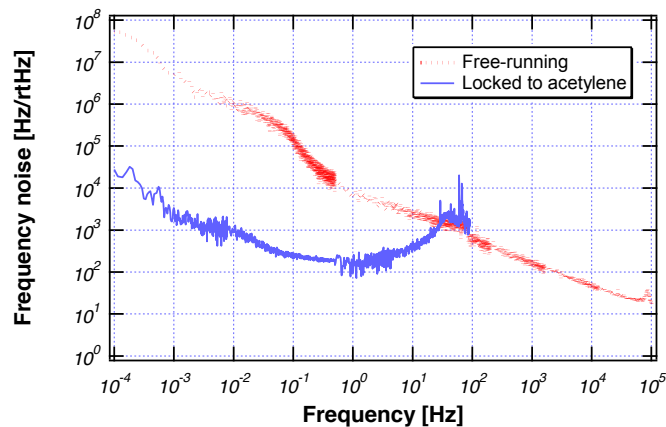

Fig. 5. Frequency noise spectrum of the PW-ECL with (solid) and without (dotted) frequency stabilization.

Figure 5 shows measured frequency noise spectrum of free-running and $^{13}\text{C}_2\text{H}_2$ -stabilized PW-ECL against Fourier frequency, f . The free-running frequency noise has $\sim 1/f^{1.0}$ and $\sim 1/f^{0.6}$ dependences below and above 1 Hz, respectively. Within the control bandwidth of ~ 60 Hz, the noise was suppressed by a factor up to ~ 1000 . The bandwidth is limited by the signal-to-noise ratio of the saturation error signal. We did not observe any loss of lock due to unstable behaviors for at least several days.

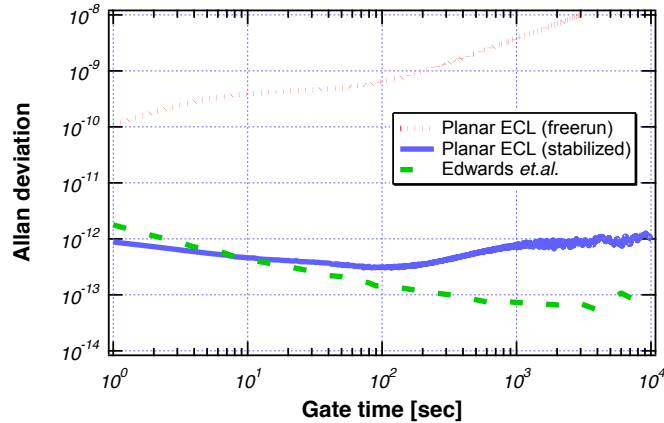

Fig. 6. Allan deviation of the PW-ECL with and without frequency stabilization. Free-running PW-ECL (dotted curve), stabilized PW-ECL (solid curve), and the best stability obtained in $^{13}\text{C}_2\text{H}_2$ system with a Littman ECL described in [16] (dashed curve) are shown.

Figure 6 shows frequency fluctuation in terms of Allan deviation. We obtained stability on the order of 10^{-13} between 1 and 10,000 sec gate time when using the acetylene frequency reference. This result was about a factor of 10 worse than one of the best results obtained in $^{13}\text{C}_2\text{H}_2$ with a Littman ECL [16], for gate time longer than 1000 sec. This higher noise is thought to be from factors not intrinsic to the PW-ECL, since the setup showed similar noise level when operated with fiber lasers [17]. Below 10 sec gate time, the short term stability appears to be around the best level measured, and is attributed to the PW-ECL's low free-running frequency noise.

4.3. Comparison of frequency noise to other lasers

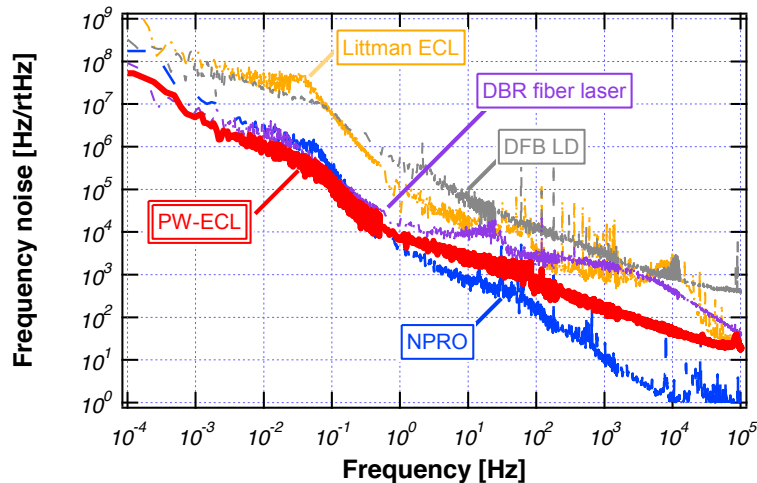

Fig. 7. Free-running frequency noise spectrum of various single-frequency lasers. PW-ECL: PLANEX from Redfern Integrated Optics (1542 nm), NPRO: Model 125 from Lightwave Electronics (1064 nm), DBR fiber laser: ROCK from NP Photonics (1542 nm), Littman ECL: Lion from Sacher Lasertechnik (1064 nm), DFB-LD: FRL15DCWD from Fitel (1578 nm).

Figure 7 compares free-running frequency noises of single frequency lasers used for precision measurements. The frequency noise of other lasers were measured using a similar setup used for evaluating the PW-ECL. The PW-ECL exhibited smaller frequency noise over the measurement range among the various types of lasers, including a Littman ECL, a distributed

feedback (DFB) laser diode, and a DBR fiber laser. Only the NPRO showed lower frequency noise than the PW-ECL, and only above about 1 Hz. We are undertaking an activity to investigate the source of excess frequency noise (relative to the NPRO), empirically studying gain chip leakage current [18] and side modes, spurious optical reflections, etc.

5. Intensity noise

Intensity noise was evaluated by monitoring the laser output with a photo-detector. Above ~ 1 Hz, we used an electrical spectrum analyzer to monitor the intensity noise spectrum directly. Below ~ 1 Hz, the photo-detector DC output was cancelled out by a stable DC source before being recorded by a computer that calculated linear spectrum density.

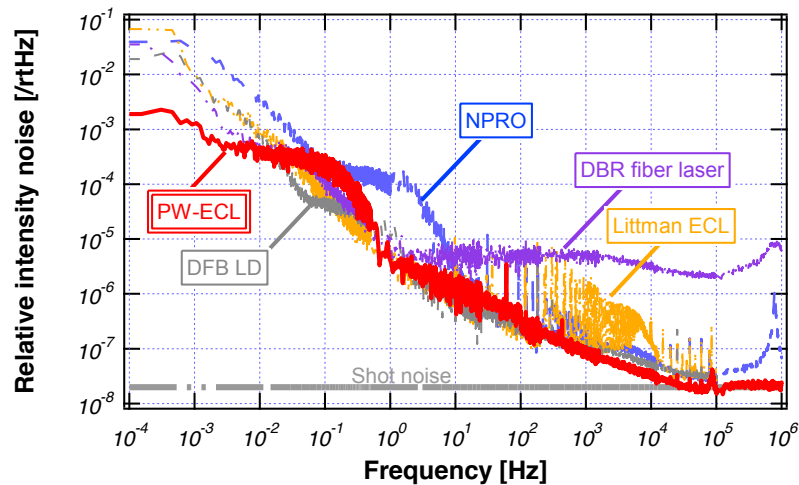

Fig. 8. Free-running relative intensity noise spectrum of various single-frequency lasers. All captions are identical to Fig. 7.

Figure 8 shows relative intensity noise (RIN) of the PW-ECL and other single-frequency lasers. Except around 0.1 Hz, the PW-ECL showed the smallest level of RIN between 0.1 mHz and 1 MHz. We suppose the noise bump around 0.1 Hz is caused by beam jitter within the package. Above 100 kHz, we confirmed that the RIN reached shot noise level ($\sim 2 \times 10^{-8}/\sqrt{\text{Hz}}$) at least up to 100 MHz.

Compared to the NPRO, the PW-ECL showed smaller RIN over the whole measurement band. The NPRO's RIN in Fig. 8 is measured with the free-space NPRO output beam falling onto a free-space detector. When the NPRO output was fiber-coupled, the RIN became larger at the output of the fiber, since the fiber coupling efficiency is sensitive to beam jitter. Also, the NPRO has a relaxation oscillation peak around ~ 700 kHz and it needs active control to be suppressed.

The RIN of semiconductor-based lasers (DFB LD and Littman ECL in Fig. 8) strongly depends on the current driver, driving mode, case temperature stability, and handling of output fiber. The RIN shown in Fig. 8 was evaluated with a standard low-noise commercial current driver in constant current mode, rather than in constant power mode, to avoid disturbing the output frequency. The Littman ECL based on a bulk grating showed RIN peaks originated from mechanical resonances around ~ 1 kHz. The PW-ECL running at constant current mode showed significantly smaller noise than those diode lasers below 10 mHz, probably because of its simple cavity structure.

A commercial DBR fiber laser showed large RIN above 1 Hz, probably because of a pump power fluctuation [19]. Also, as shown in Fig. 8, the RIN of a fiber laser has a relaxation oscillation peak typically between 100 kHz and 1 MHz at a level of $\sim 10^{-5}/\sqrt{\text{Hz}}$ [20,21], and it needs to be actively suppressed for precision measurements. In contrast, RIN peaks due to

relaxation-oscillation and adjacent laser modes are at > 7 GHz at a level of $<10^{-7}$ $\sqrt{\text{Hz}}$ in the PW-ECL.

6. Discussions

In this section, we discuss other features of the PW-ECL, which should be taken into account in the design of precision measurement systems.

6.1 Frequency tuning bandwidth

In many precision measurements that use a laser frequency as a reference, the laser frequency must be controlled within a wide bandwidth. For example, frequency locking to high-finesse cavity and phase locking between two lasers would require wider control bandwidth than demonstrated here (~ 60 Hz). The PW-ECL's frequency tuning response (~ 2 kHz) may not be fast enough by itself to suppress the large frequency noise at higher frequency (relative to the NPRO).

The tuning response could be internally improved by adding a fast electro-optically-driven phase section within the laser cavity. An external fiber-coupled waveguide phase modulator can also be used as an AC-coupled frequency actuator. We have successfully integrated such a system and acquired stable phase lock between two PW-ECLs with ~ 1 MHz bandwidth.

6.2 Output power and wavelength

In precision measurements, output power, controllability, and selection of lasing wavelength are other important factors to be considered.

When the injection current is already used as a frequency actuator in the PW-ECL, there is no independent intensity actuator available. An external intensity actuator, such as a waveguide Mach-Zehnder modulator, a semiconductor optical amplifier, or an AOM, may be required in order to control frequency and intensity at the same time.

The output power of the PW-ECL is limited to ~ 15 mW by the gain chip output and the loss within the laser cavity. When higher output power is required, it can be boosted by, for example, a fiber amplifier. Intensity noise introduced by the fluctuation of the amplifier pump power can be suppressed by controlling the amplifier pump current as an intensity actuator below 1 kHz [22].

At present, the output wavelength is limited to the telecom C-band due to the material and dopants of the InP gain chip. It can be expanded to other wavelengths by using appropriate gain chips (for example, GaAs for 1- μm band) and different Bragg reflectors. Theoretically, the PW-ECL design should be adaptable to any wavelength between visible and near-infrared, just like ECLs based on bulk gratings. A longer-term research goal is to demonstrate this wavelength adaptability, which would significantly expand the range of PW-ECL applications.

7. Conclusions

We have demonstrated that the PW-ECL has low enough frequency noise, intensity noise, and high stability needed for precision measurements, in which other types of more expensive lasers have been used. It was tested in a frequency stabilization loop that is based on saturation spectroscopy of acetylene molecule, and showed high stability. Compactness of the package, low cost, simple design, low-parts count and high stability of the PW-ECL could make it an attractive option for use in various precision applications including optical frequency standards and space missions.